

Clarke®



ENGINE SUPPORT

MODEL NO: CEC500DS

PART NO: 7612912

USER & MAINTENANCE INSTRUCTIONS



GC0813

INTRODUCTION

Thank you for purchasing this CLARKE Engine Support, designed to support and position engines during maintenance operations such as replacing anti-vibration mountings and as an aid to removing transmissions.

Before attempting to use this product, please read this manual thoroughly and follow the instructions carefully. In doing so you will ensure the safety of yourself and that of others around you, and you can look forward to your purchase giving you long and satisfactory service.

IMPORTANT: Please read all of the safety and operating instructions carefully before using this product. Please pay particular attention to all sections of these instructions that display warning symbols and notices.



WARNING: THIS SYMBOL IS USED THROUGHOUT THE USER GUIDE WHENEVER THERE IS A RISK OF PERSONAL INJURY. ENSURE THAT THESE WARNINGS ARE READ AND UNDERSTOOD AT ALL TIMES.

SPECIFICATION

Rated Load	500 kg
Lifting Hook Width Adjustment	80-620 mm
Dimensions (D x W x H)	85 x 1500 x 270 mm
Product Weight	18.75 kg
Chain Length	930 mm
Adjustable Foot Width	750 - 1450 mm

GUARANTEE

This product is guaranteed against faulty manufacture for a period of 12 months from the date of purchase. Please keep your receipt which will be required as proof of purchase.

This guarantee is invalid if the product is found to have been abused or tampered with in any way, or not used for the purpose for which it was intended. Faulty goods should be returned to their place of purchase, no product can be returned to us without prior permission. This guarantee does not effect your statutory rights.

GENERAL SAFETY RULES

Before using your engine support, it is in your own interest to read and comply with the following safety rules.

1. Keep the work area clean. Cluttered areas invite injuries. Keep the work area well lit.
2. Keep children away. Children must never be allowed in the work area.
3. Store idle equipment. When not in use, tools must be locked up in a dry location to inhibit rust. Always lock up tools and keep out of reach of children.
4. Dress properly. Do not wear loose clothing or jewelry which could be caught in moving parts.
5. Use eye and hand protection. Always wear approved impact safety goggles.
6. Watch what you are doing and use common sense. Do not use any tool when you are tired.
7. Check for damaged parts. Before using any tool, any part that appears damaged should be carefully checked to determine that it will operate properly and perform its intended function.
8. Do not use this equipment if under the influence of alcohol or drugs. If there is any doubt, do not operate the tool.
9. Always keep bystanders well clear.
- 10. Never exceed the safe working load of 500 kg.**
11. Use only slings or chains with a capacity equal to, or greater than that of the engine support.
12. Ensure the operator is familiar with both operational and safety aspects.
13. Before supporting a load, ensure all bolts and lock knobs are fully tightened.
14. Always check to ensure that any sling or chain used is properly secured and that it cannot cause damage to engine components as the weight is taken by the engine support.
15. Inspect the engine support before use to ensure it is in good condition. Replace any damaged or worn parts.
16. If replacing parts, only use those supplied by Clarke International.

PRODUCT OVERVIEW

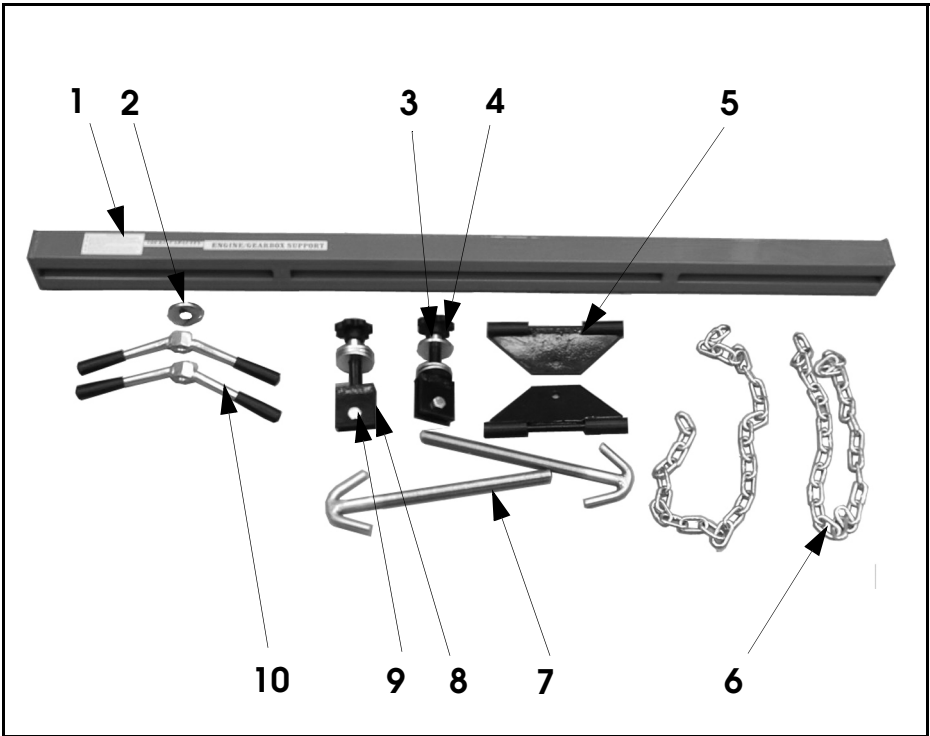

NO	DESCRIPTION
1	Support Beam
2	Washer (large hole)
3	Washer (small hole)
4	Knob
5	End Plate

NO	DESCRIPTION
6	Chain
7	Lifting Hook
8	Support Block
9	Bolt (M12 x 25)
10	Handle

ASSEMBLY

1. Attach the support blocks (8) to the end plates (5) with the bolts (9).
2. Slide the threaded end of the support blocks through the channel in the support beam (1). As it emerges, place a washer (3) onto the thread and screw on the knob (4), but do not tighten down.
3. Pass the threaded section of the lifting hooks through the channel in the support beam.
4. Place the washers (2) on to the threads of the lifting hooks (7) and screw on the handles (10).
5. Your engine support is now ready for use.

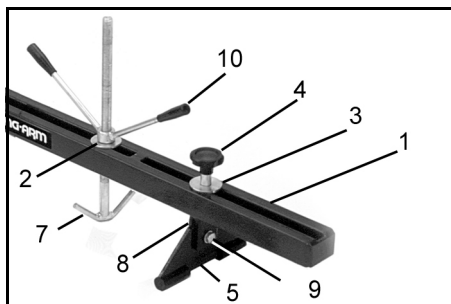
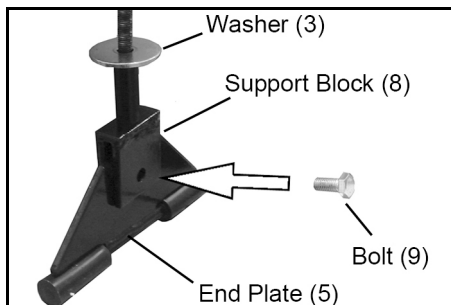

OPERATION

Before use, check to ensure that the engine weight, or engine plus gearbox weight, does not exceed the rated capacity of the engine support.

Make sure that the front panel gutters of the vehicle are in good condition and are capable of supporting the engine load.

1. Place the support beam across the engine bay with the end plates securely located in the gutters of the front wing panel. (Slide the end plates in the beam channel, until they align with the gutters. Ensure all the weight is taken by the gutters, not on any surface of the wings).
2. Lower the lifting hooks down through the slot in the beam.

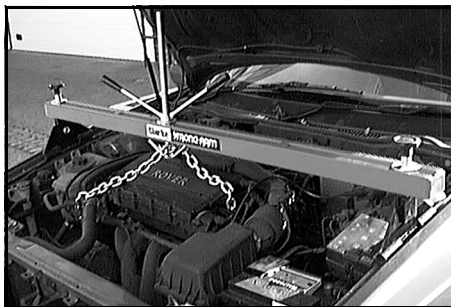

3. If possible, attach the chains provided, directly onto the engine lifting points. Refer to the manufacturers handbook to identify the attachment points.
4. Otherwise, attach an appropriate sling or chain to the engine lifting points, and then attach these to the chain provided. Wrap the chain around the lifting hooks.
5. Manoeuvre the chain/sling so that the lift will be even, in order for the engine to be held level and square once the engine mountings have been removed.
6. Once satisfied that the arrangement is secure, tighten the knobs, then turn the handles to raise the lifting hooks, which will take the weight of the engine. Do not to continue if the engine or engine/gearbox assembly is not free to move.

NOTE: Tensioning is usually carried out immediately prior to the final release of the engine mountings. To judge if the weight has been taken sufficiently, slacken off the engine mounting bolts before tensioning the engine support. Then, as you continue to unscrew the engine mounting bolts, turn the handle until you find the spot where they are easiest to turn. This indicates that full weight is taken by the engine support. You may have to turn the handles to and fro a few times until the correct position is found.

IMPORTANT: When turning the handle to take the load, pay particular attention to the chain/sling arrangement to ensure that no damage occurs to engine components as the chain/sling tightens.

7. Do not leave the engine support unattended whilst it is supporting the weight of the engine.
8. Wherever possible, use both slings in order to help spread the weight of the engine.

MAINTENANCE

Always inspect the equipment before use for visible signs of damage, worn or missing parts.

Check the beam for cracks and distortion.

Inspect the chains and hooks for damage or distortion. If any is apparent have them replaced.

DECLARATION OF CONFORMITY



Clarke[®]
INTERNATIONAL

Hemnall Street, Epping, Essex CM16 4LG

DECLARATION OF CONFORMITY

This is an important document and should be retained.

We hereby declare that this product(s) complies with the following directive(s):

2006/42/EC Machinery Directive.

The following standards have been applied to the product(s):

EN 14121-1:2007, EN ISO 12100-1:2003+A1:2009, EN ISO 12100-2:2003+A1:2009

The technical documentation required to demonstrate that the product(s) meet(s) the requirement(s) of the aforementioned directive(s) has been compiled and is available for inspection by the relevant enforcement authorities.

The CE mark was first applied in: 2010

Product Description: 500KG ENGINE SUPPORT
Model number(s): CEC500DS
Serial / batch Number: N/A
Date of Issue: 15/10/12

Signed:



J.A. Clarke
Director

A SELECTION FROM THE VAST RANGE OF

Clarke®

QUALITY PRODUCTS

AIR COMPRESSORS

From DIY to industrial, Plus air tools, spray guns and accessories.

GENERATORS

Prime duty or emergency standby for business, home and leisure.

POWER WASHERS

Hot and cold, electric and engine driven - we have what you need

WELDERS

Mig, Arc, Tig and Spot. From DIY to auto/industrial.

METALWORKING

Drills, grinders and saws for DIY and professional use.

WOODWORKING

Saws, sanders, lathes, mortisers and dust extraction.

HYDRAULICS

Cranes, body repair kits, transmission jacks for all types of workshop use.

WATER PUMPS

Submersible, electric and engine driven for DIY, agriculture and industry.

POWER TOOLS

Angle grinders, cordless drill sets, saws and sanders.

STARTERS/CHARGERS

All sizes for car and commercial use.



PARTS & SERVICE: 020 8988 7400

E-mail: Parts@clarkeinternational.com or Service@clarkeinternational.com

SALES: UK 01992 565333 or Export 00 44 (0)1992 565335

Clarke® INTERNATIONAL Hemnall Street, Epping, Essex CM16 4LG
www.clarkeinternational.com